

Industrieprodukte
Produits pour l'industrie

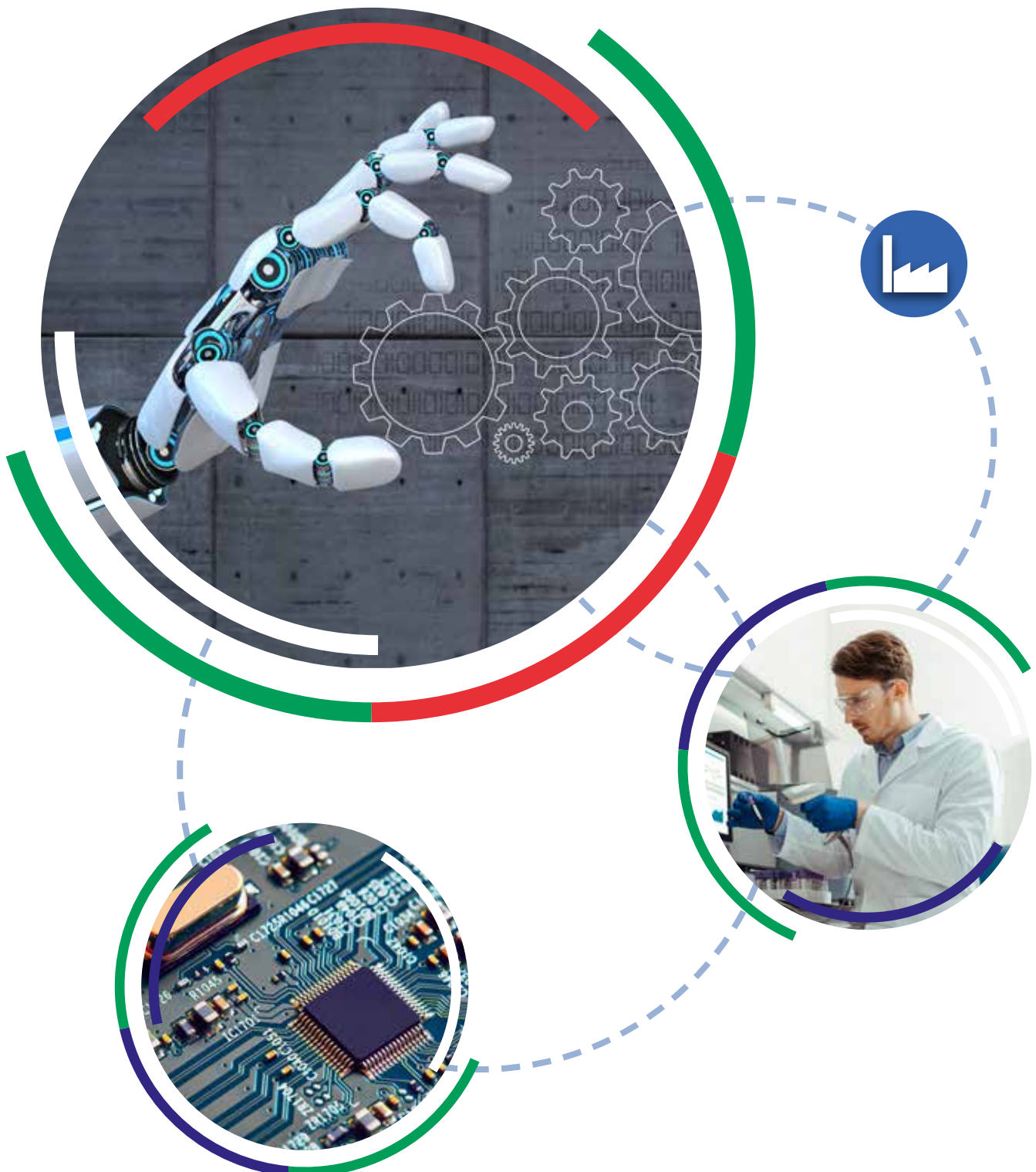



FERRATEC

Ferratec AG
Grossmattstrasse 19
CH-8964 Rudolfstetten

Tel.: 056 649 21 21
Fax: 056 649 21 41

info@ferratec.ch
www.ferratec.ch



EastTec

EASTtec components. s.r.o
Bratislavská 40
CZ-69002 Breclav

Tel.: +420 533 38641 0
Fax: +420 533 38641 1

info@easttec.cz
www.easttec.cz

FERRATEC

FERRATEC AG – „Komponenten mit System“

Die FERRATEC AG ist ein familiengeführtes KMU, das mit 50 Mitarbeitern hochwertige Markenprodukte und Dienstleistungen für verschiedene Kundensegmente in Installationstechnik, Industrie und Mechanik anbietet. Mit intensiver Betreuung und fachkundiger Beratung finden wir gemeinsam mit unseren Kunden die optimale Lösung für die geforderte Anwendung. Qualität, Kompetenz und Flexibilität stehen für uns an oberster Stelle.

FERRATEC AG – « Liaison avec la technique »

FERRATEC AG est une PME familiale comptant 50 employés qui propose services et produits de haute qualité dans les domaines de l'installation, de l'industrie et de la mécanique. Grâce à notre assistance continue et à des conseils avisés, nous trouvons, avec nos clients, la solution optimale pour leur application. Qualité, compétence et flexibilité sont nos priorités absolues.

An ISO certified company.

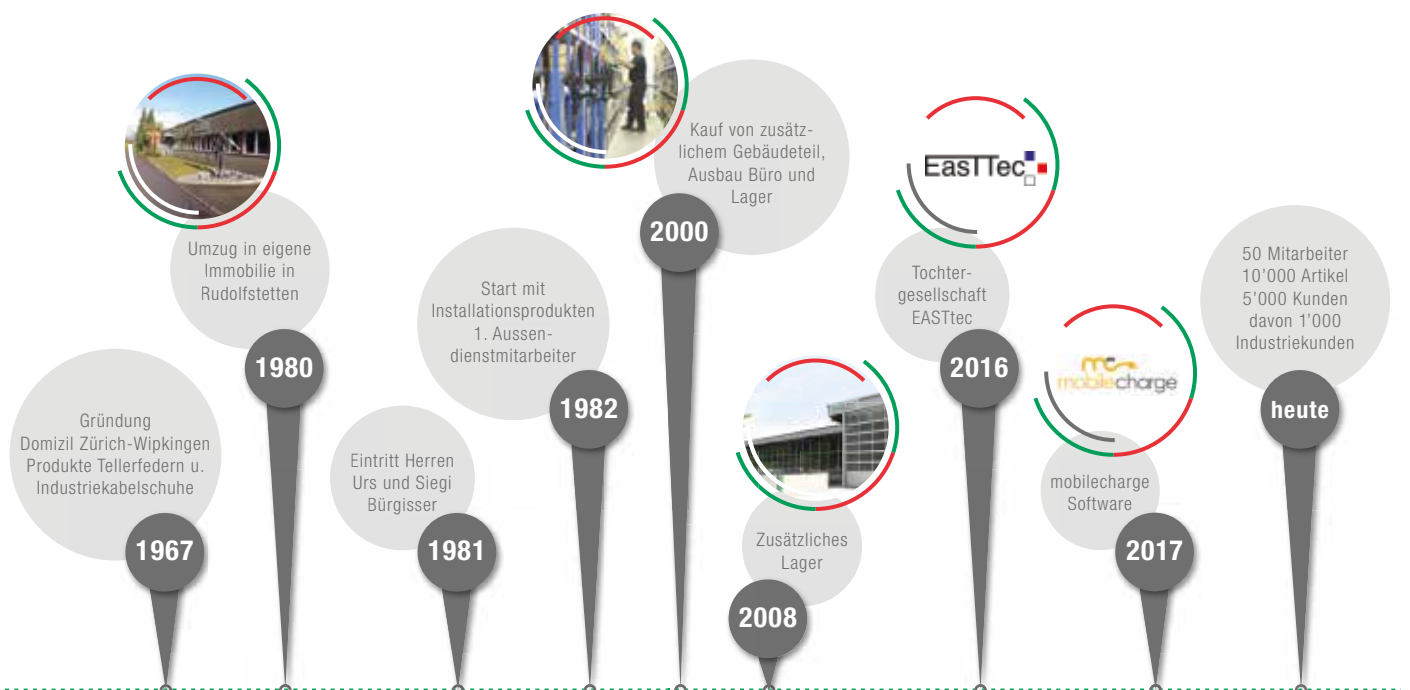

FERRATEC

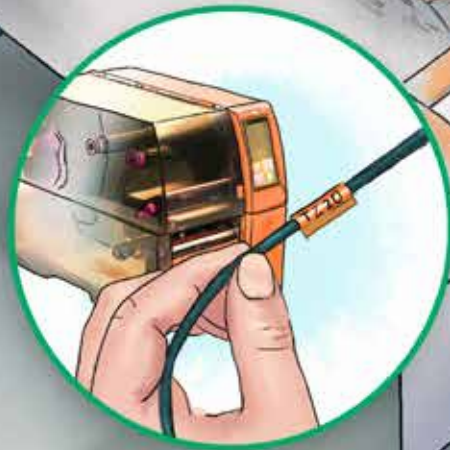
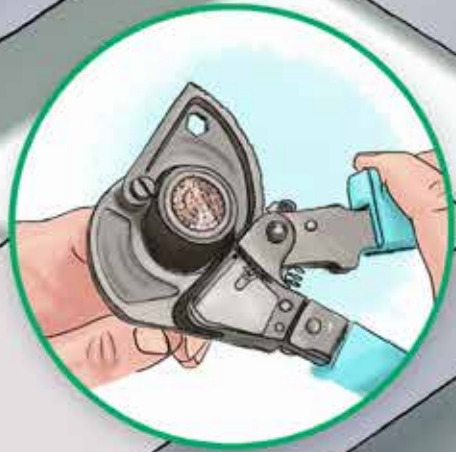

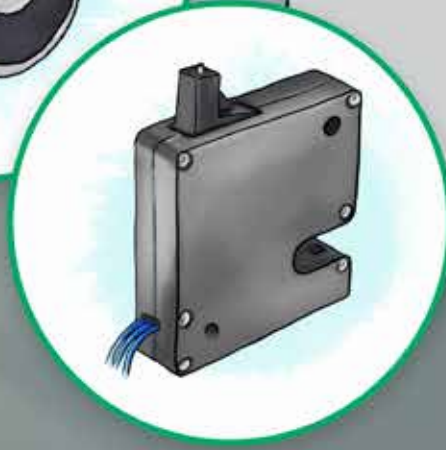
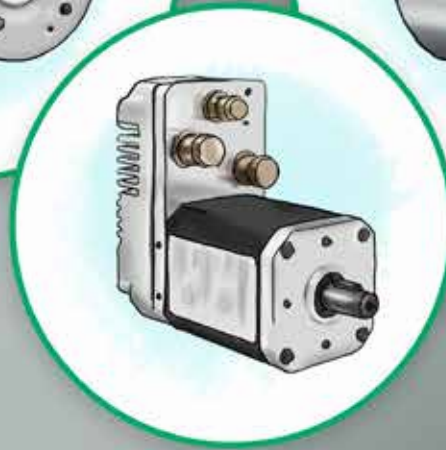
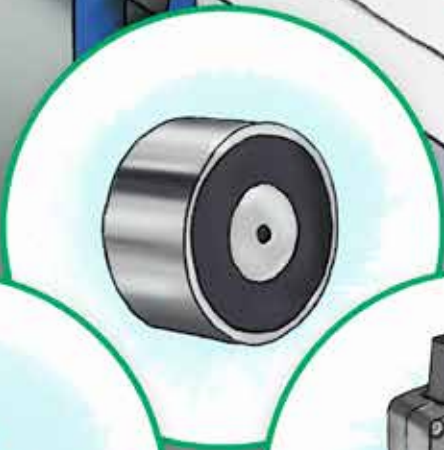
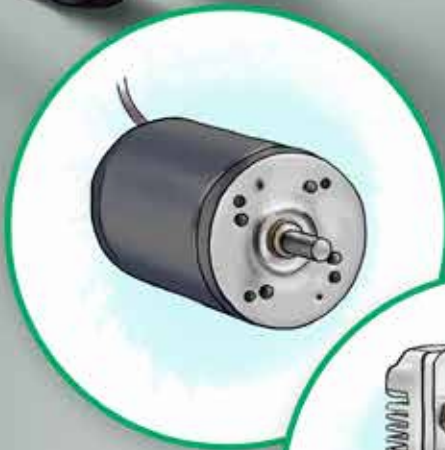
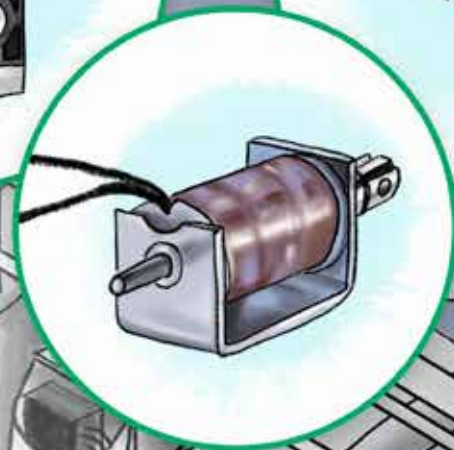
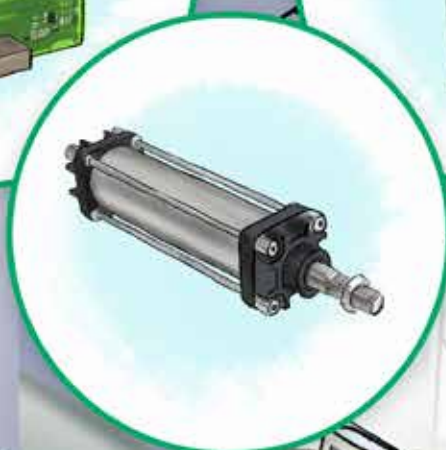
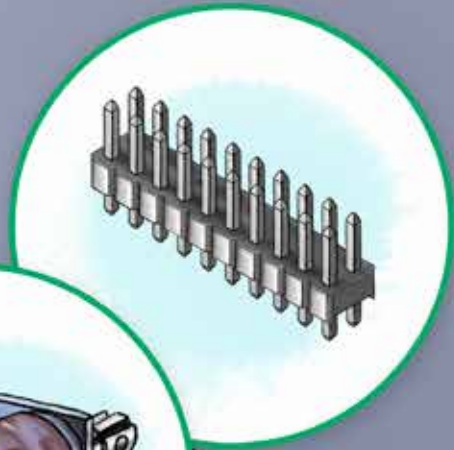
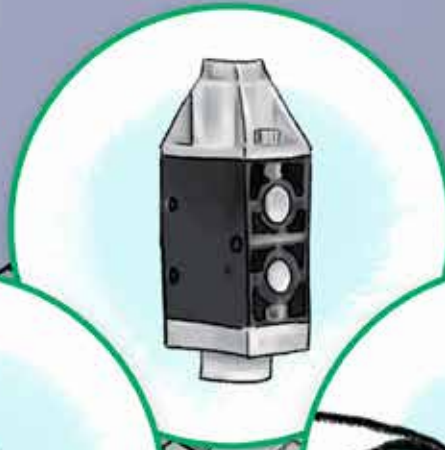
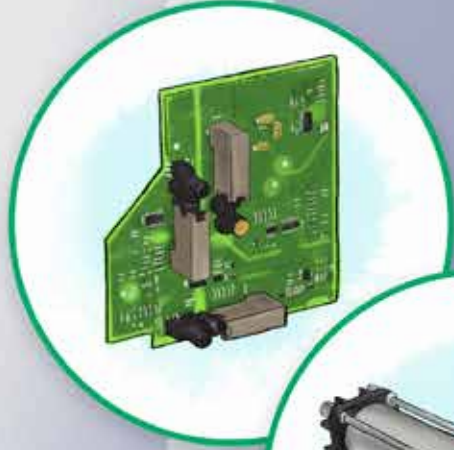



Leiterplattenklemmen

Für gedruckte Schaltungen
THT, SMD und THR

Borniers

Pour circuit imprimé
THT, SMD et THR

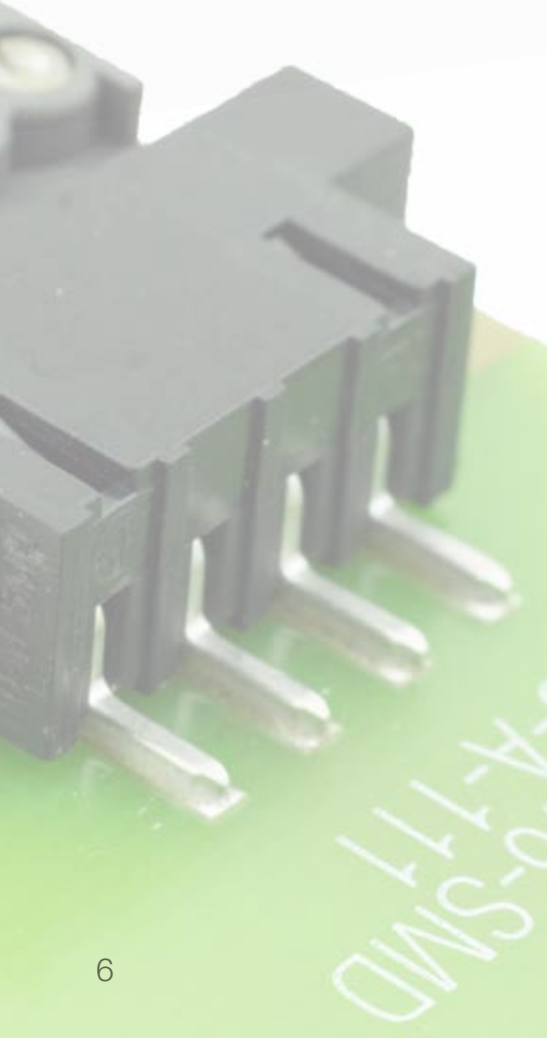

Steckverbindersysteme

Steckerleisten mit Schraubanschluss
und passenden Stiftleisten

Système de raccordement par connecteur

Barrette de connexion à vis et
connecteur mâle correspondant

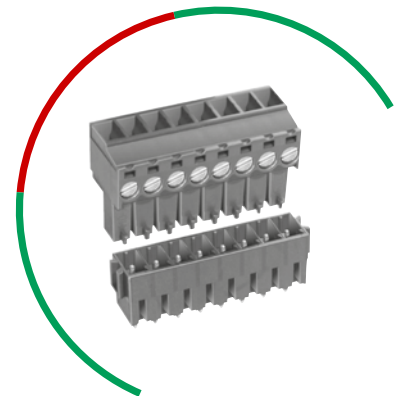

Klemmleisten

Buchsenklemmen oder schraublose
Klemmstecker

Barrettes

Bornes à douille ou bouchons de
serrage sans vis

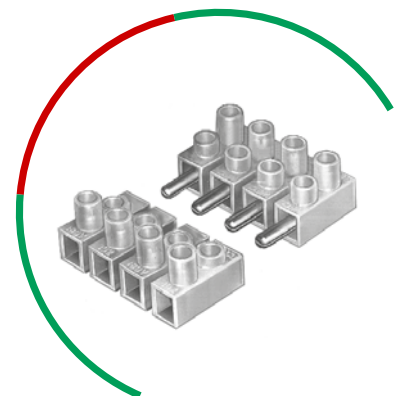

Kundenspezifische Lösungen

Zum Beispiel Einlegeteil mit
4 Flachsteckern, IP 54

Solutions sur demande client

Par ex. insert avec 4 fiches mâles,
IP54

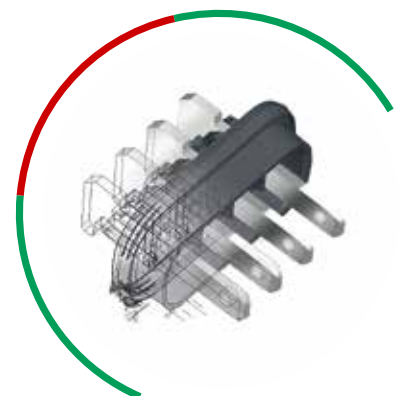

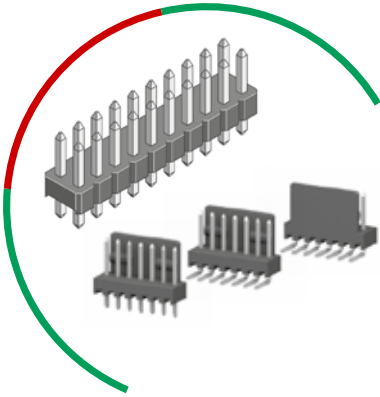
**Stiftleisten**

Für Leiterplatten und wire to board

Barrettes

Pour circuits imprimés et wire to board

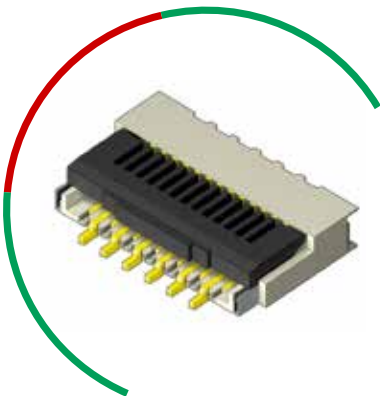
**FFC / FPC**

Verbinder für Flachkabel

FFC / FPC

Connecteurs pour câbles plats

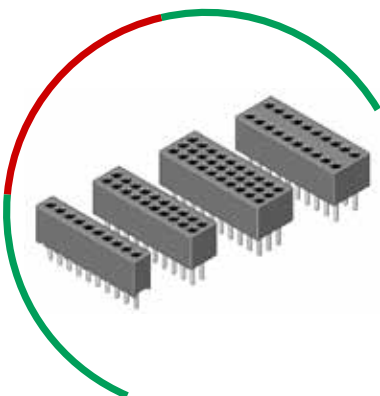
**Buchsenleisten**

Mit gedrehten Kontakten

Barrettes femelles

Avec contacts de précisions usinés

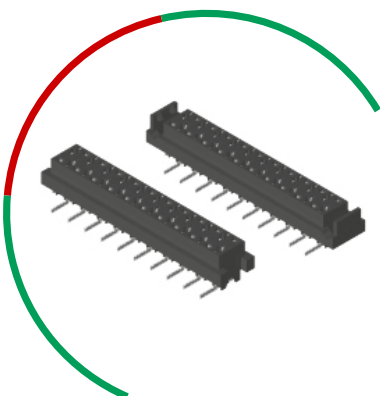
**Buchsenleisten**

Für wire to board Verbindungen

Barrettes femelles

Pour connexions fils sur circuits



Stift- und Buchsenleisten

SMD

Barrettes mâles et femelles

SMD

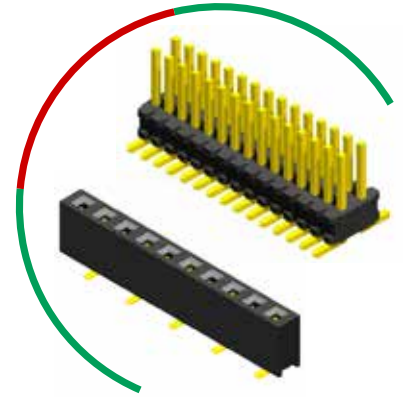

Kurzschlussbrücken

In allen Variationen

Cavaliers

Dans toutes les variantes



Optoelektronik LWL

Sender und Empfänger

Optoélectronique LWL

Emetteurs et récepteurs

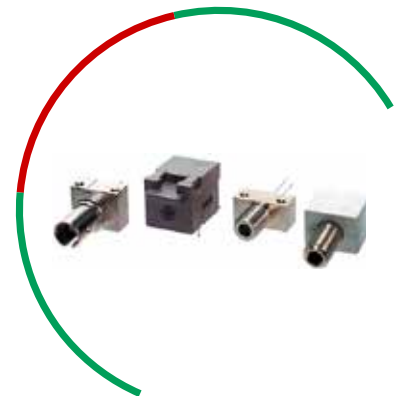

Optoelektronik LWL

Lösungen

Kabel konfektioniert, POF, PCF, GOF

Optoélectronique LWL

Câbles confectionnés, POF, PCF, GOF





Bürstenmotoren DC

DCmind, leise und kraftvoll

Moteurs DC à balais

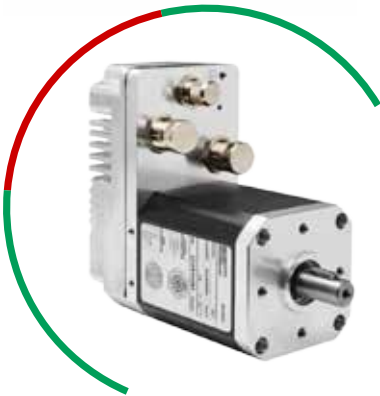
DCmind, silencieux et puissants



Bürstenlose Motoren DC

DCmind, programmierbares

Kraftpaket

Moteurs DC sans balais

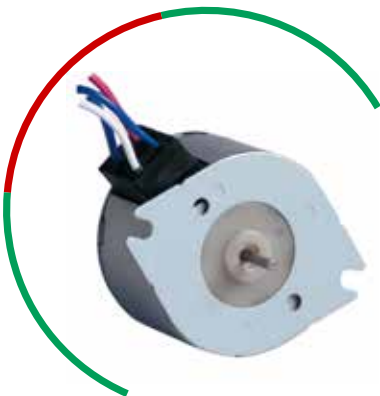
DCmind, puissance programmable

Schrittmotoren

Moteurs pas à pas

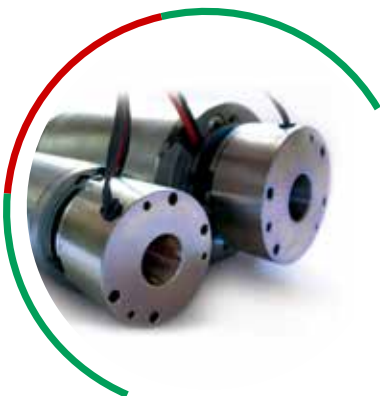

Zubehör

Getriebe, Bremsen, Encoder etc.

Accessoires

Transmissions, Freins, Codeurs etc.

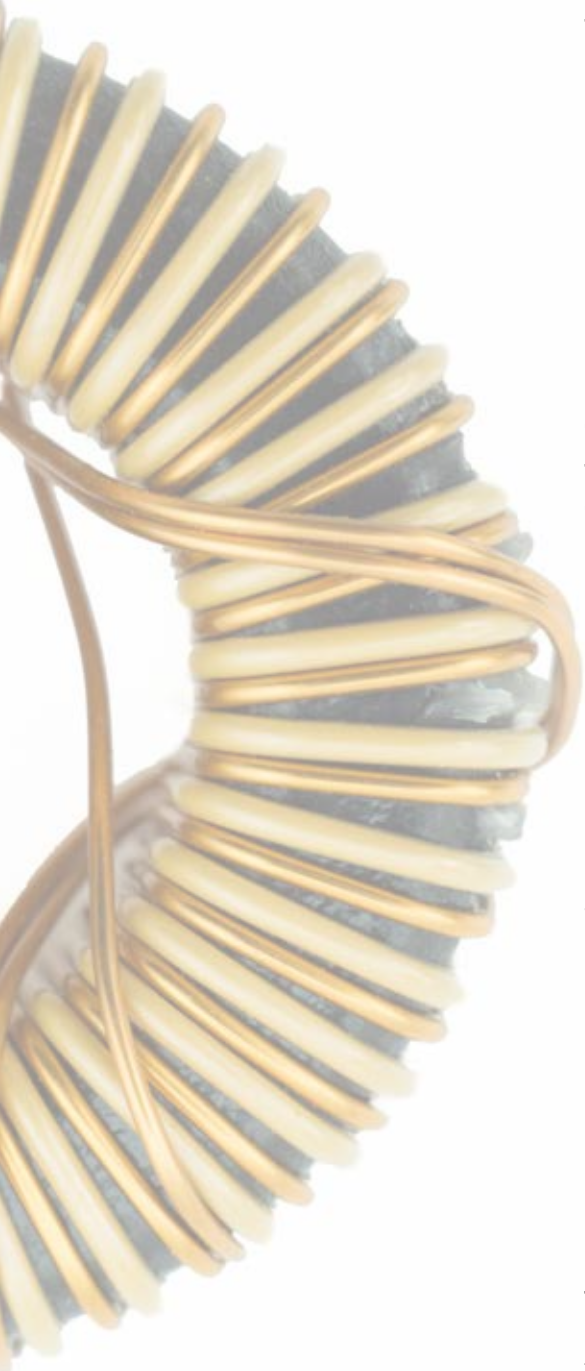



Transformatoren
im Gehäuse, vergossen

Transformateurs
en boîtiers coulés



MSE Transformatoren
0.5... 325 VA

Transformateurs ouverts
0.5... 325 VA



Spulen
Bobines



Transformatoren
kundenspezifische Lösungen
für Gross- und Kleinserien

Transformateurs
sur mesure pour applications
grandes et petites séries

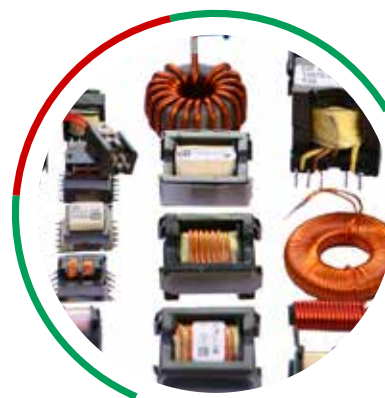

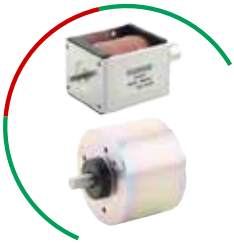

Hubmagnete

Rund / Quadratisch
Bistabil / Monostabil
Einfachhub / Umkehrhub

Aimants de levage

Ronds/carrés
Bistables/monostables
Levage simple/aller-retour

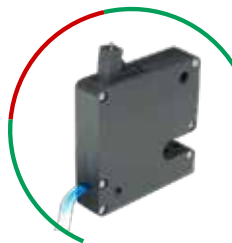

Magnetschloss

Mono- oder bistabil
Hohe Lebensdauer, IP44

Verrou magnétique

Mono ou bistable
Longue durée vie, IP44



Bremsen und Kupplungen

Federkraft- und Permanentmagnet-Bremsen
Elektromagnetische- und Magnetpulver- Kupplungen

Freins et embrayages

Freins à ressort et à aimants permanents
Embrayages magnétiques et embrayage à particules magnétiques

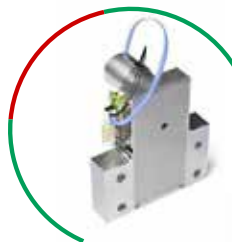

Laser Shutter

Einfache oder komplexe Systeme

Obturbateurs à laser

Systèmes simples ou complexes



Haftmagnete

Stabförmig/Rund
Mit oder ohne Permanentmagnet
Türhaftmagnete

Aimants de maintien

En forme de tige/rondes
Avec ou sans aimant permanent
Aimants de maintien de porte



Schwingmagnete

Wurfvibratoren, Rüttler, Linearvibratoren, Bogenvibratoren

Aimants oscillants

Vibrateurs-jeteurs, vibrateurs, vibrateurs linéaires, vibrateurs de courbe



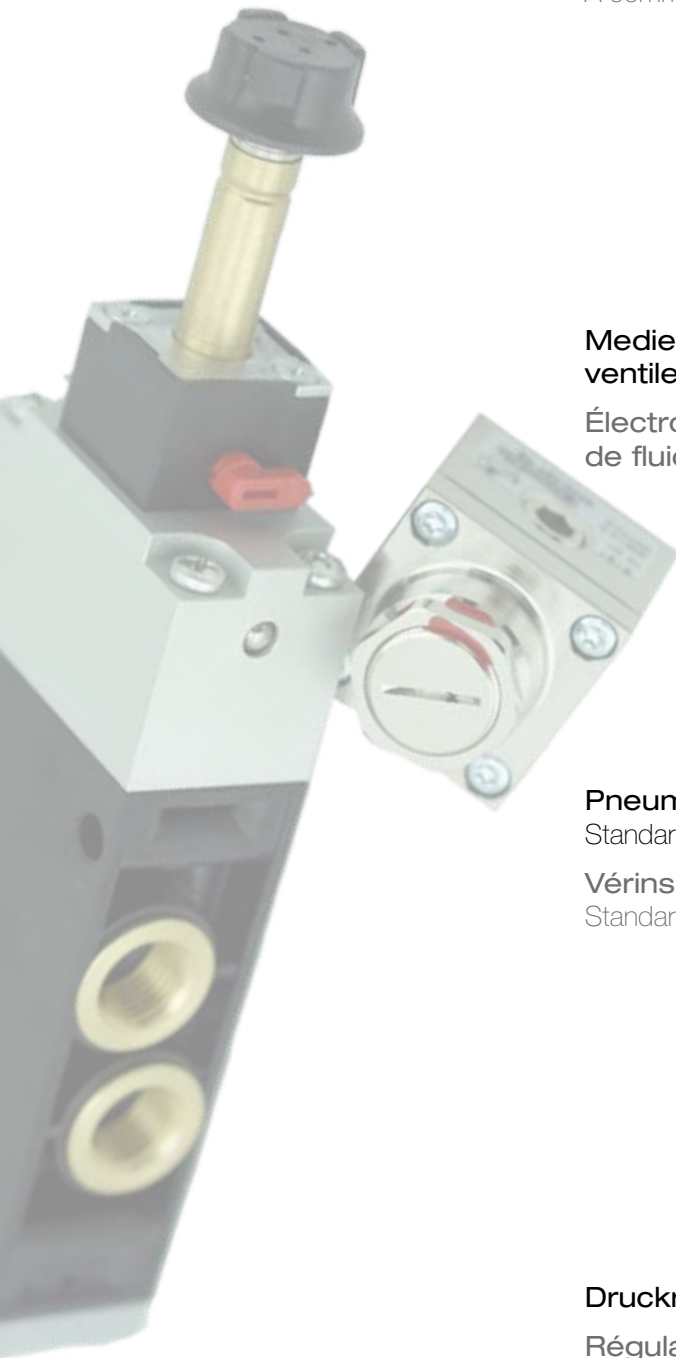

Magnet- und Proportionalventile

Direkt- oder vorgesteuert

Électrovannes

À commande directe ou pilotées



Mediengetrennte Magnet-ventile

Électrovannes à séparation de fluides



Pneumatik Zylinder

Standard und Sonderlösungen

Vérins pneumatiques

Standard et solutions spéciales

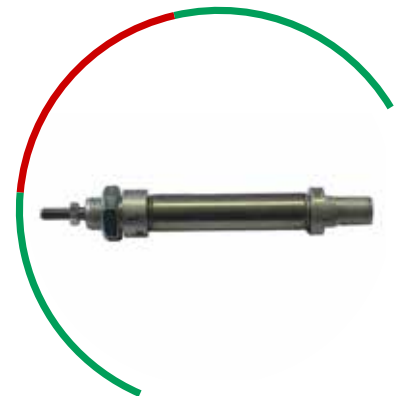

Druckregler

Régulateurs de pression



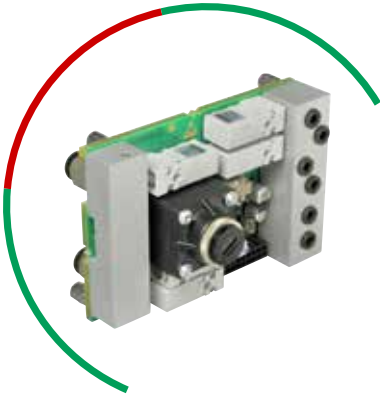

AirBoard®

- Träger aus mehrschichtiger Leiterplatte aus FR4
- Eingefräste, beschichtete Kanäle für den Gas-/Luftfluss
- SMD- oder THT-Bauteile ein- oder beidseitig auf der Leiterplatte

AirBoard®

- Support constitué par une carte à circuit imprimé multicouche en FR4
- Canaux fraisés et revêtus pour le flux de gaz/d'air
- Composants SMD ou THT sur un ou les deux côté(s) de la carte à circuit imprimé



FluidBoard®

- Laserverschweisste Kunststoffplatten
- Auswahl verschiedener Kunststoffe für den Einsatz aggressiver Medien
- Aufgebrachte Leiterbahnen ermöglichen Integration elektronischer Bauteile

FluidBoard®

- Constitué de plaques de plastique soudées au laser
- Le vaste choix de plastiques utilisables permet de l'utiliser avec les fluides les plus divers, notamment des fluides agressifs
- L'application de structures de pistes conductrices permet d'intégrer des composants électroniques dans le FluidBoard®

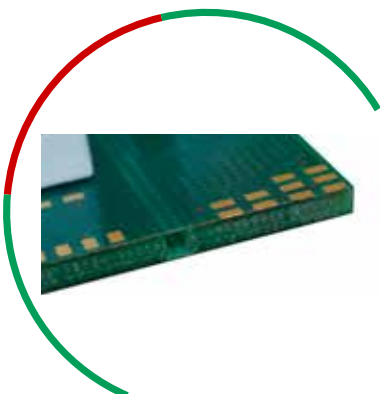

Diese vergrößerte Aufnahme zeigt einen Kanal innerhalb des AirBoards®, durch den gasförmige Medien geführt werden. FluidBoard® besteht aus laserverschweissten Kunststoffplatten.

Cette vue agrandie montre un canal à l'intérieur de l'AirBoard® à travers lequel les gaz sont conduits. Le FluidBoard® est constitué de plaques de plastique soudées au laser.

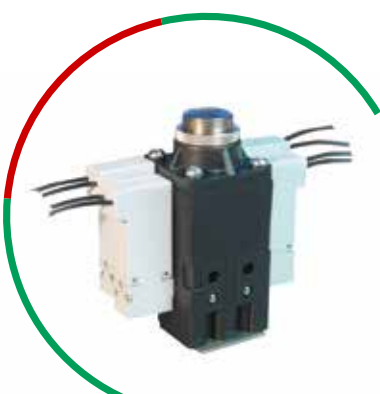

Mechanische Ventilbaugruppen

- Plug-and-Play Lösungen bis zum erweiterten Ventilblock
- Kosteneffiziente Lösungen für verschiedenste Anwendungen

Ensembles de vannes mécaniques

- Solutions plug & play jusqu'au bloc de vannes élargi
- Solutions économiques pour les applications les plus diverses

Kabel & Zubehör Câbles et accessoires



Litzen und Kabel

Nach MIL, EN, BMS, VG
Kabelbau nach Kundenwunsch

Fils et câbles

Selon MIL, EN, BMS, VG
Confection selon désirs du client



Wärmeschrumpfschläuche und -verbinder

Auf die Anwendung zugeschnitten

Gaine thermorétractable et manchons à souder

Longueur selon vos besoins



Formteile für Verzweigungen und Gehäusedurchführungen

Standard sowie Sondergrößen

Pièces moulées pour dérivations et passage

Standard ou sur mesure



Drucker & Markierungen

Für Schrumpfschläuche und Kabel

Imprimantes & Marquage

Pour gaine et câble



Rundsteckverbinder

Für höchste Anforderungen

Connecteur circulaire

Pour les exigences les plus élevées





Tellerfedern

Für kleine und grosse Federkräfte

Rondelles-ressort

Petite et grande force de pression



Tellerfedersäulen

Für grössere Federwege

Rondelles-ressort en colonne

Pour grandes courses

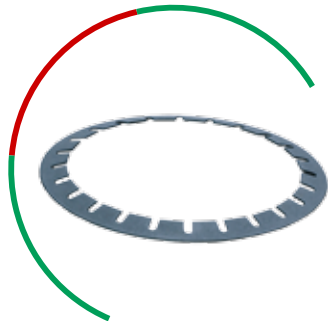

Kugellager-Tellerfedern

Für die axiale Vorspannung

Rondelles-ressort pour roulements à billes

Pour pré-tension axiale

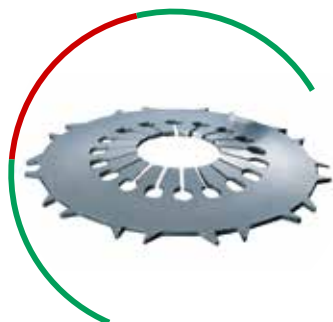

Hochpräzise Formteile

Präzision nach Mass

Rondelles à formes

Haute précision sur mesure



Teile für Flügelzellenpumpen

Für Druck bis 150 bar

Pièces pour pompe à ailettes

Pour pression jusqu'à 150 bars





Mira 32
Elektrisches Abisolieren

Mira 32
Dénudage électrique



Mira 230 / Mira 230Q
Gesichertes Abisolieren

Mira 230 / Mira 230Q
Stripping le plus sécurisé



Mira 340
Die smarteste Art der
Mehrliterverarbeitung

Mira 340
La manière la plus intelligente
d'usiner des câbles
multiconducteur



Iota 330
Universelle Schneidemaschine

Iota 330
Machine de coupe universelle



WDT UP 14 ZLW
Pneumatische Crimpmaschine

WDT UP 14 ZLW
Machines à sertir pneumatique



WDT UP 35
Pneumatische Crimpmaschine

WDT UP 35
Machines à sertir pneumatique



WDT UP 65
Hydraulische Crimpmaschine

WDT UP 65
Machines à sertir pneumatique



WDT UP 150
Hydraulische Crimpmaschine

WDT UP 150
Machines à sertir pneumatique



Crimpwerkzeuge
Outils de sertissage



Seitenschneider
Pincés coupantes diagonales

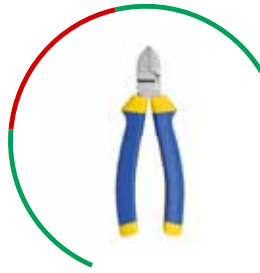

Schneidwerkzeuge
Cisailles



Abisolierzangen
Pincés à dénuder



Presswerkzeuge
Outils de sertissage



Heissluftfön
Pistolet à air chaud

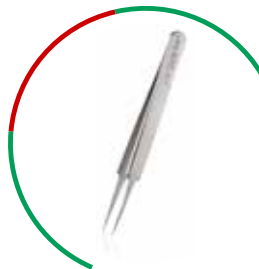

Pinzetten
Brucelles



Kabelbeschriftungsmaschinen
Machines de marquage de câbles



Drucksensoren
Capteurs de pression

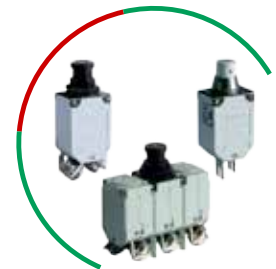

Sicherungsautomaten
Coupe-circuits automatiques



Kabelschuhe mit und ohne Isolation
Cosses isolées et non isolées



Aderendhülsen isoliert und nicht isoliert
Embouts isolés et non isolés



Abdeckkappen und Kabeldurchführungen
Caches & Passe-câble et bouchons



Kabelbinder
Serre-câbles

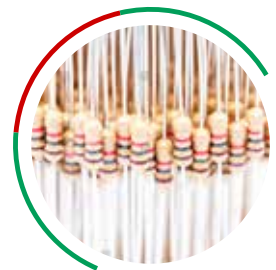

Passive Elemente
Éléments passifs

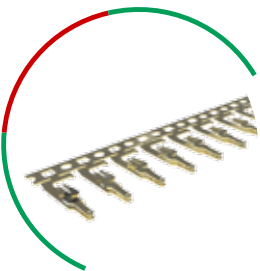

Leadframes

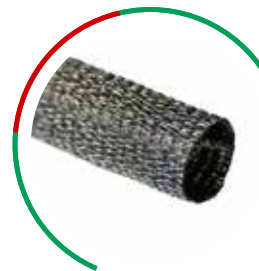

Geflechschläuche
Gainés souples

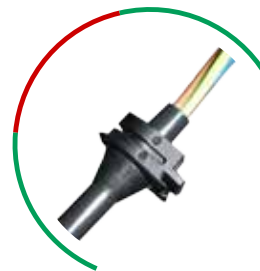

Aufspritzung von Formteilen
Moulage de pièces



Kabelkonfektionen
Confections de câbles



CEE-Steckvorrichtungen, Kombinationen, E-Mobilität
Prises et fiches CEE, combinaisons et E-mobilité

Ferratec bietet Ihnen massgeschneiderte Dienstleistungen:
Ferratec vous propose des services sur mesure:

Design in – unsere Kernkompetenz

- Plug and Play Lösungen
- Anpassung vorhandener Produkte unseres breiten Sortiments
- Produktneuentwicklungen für spezielle Bedürfnisse
- Zusammenwirken zwischen Ihren Ideen und unserem Know-how und Netzwerk

Conception - Notre compétence-clé

- Solutions plug & play
- Adaptation de produits existants de notre vaste gamme de produits
- Modification de produits pour des besoins spéciaux
- Synergie entre vos idées ainsi que notre savoir-faire et notre réseau



Kitting

- Vendor Consolidation
- Senkung Ihrer Rüstzeiten, Materialtransporte und Prozesszeiten
- Vereinfachung für Ihre Produktion
- Zuverlässige Disponierung und Verfügbarkeit

Kitting

- Rationalisation de vos fournisseurs
- Réduction de vos temps de préparation, transports de matériaux et temps de traitement
- Simplification pour votre production
- Mise à disposition fiable et disponibilité

Kabelkonfektion

- Von vorgreifenden Arbeiten bis zum anschlussfertigen Kabel
- Verringerter Prozessaufwand und Stücklistenverwaltung
- Vorzugskonditionen mit kurzfristiger Verfügbarkeit
- Flexibilität auch bei Prototypen und Kleinstmengen

Confection de câbles

- Des travaux de préparation jusqu'aux câbles prêts à être raccordés
- Coût de traitement réduit et gestion des listes de pièces
- Conditions préférentielles avec une mise à disposition rapide
- Flexibilité également pour les prototypes et les très petites quantités





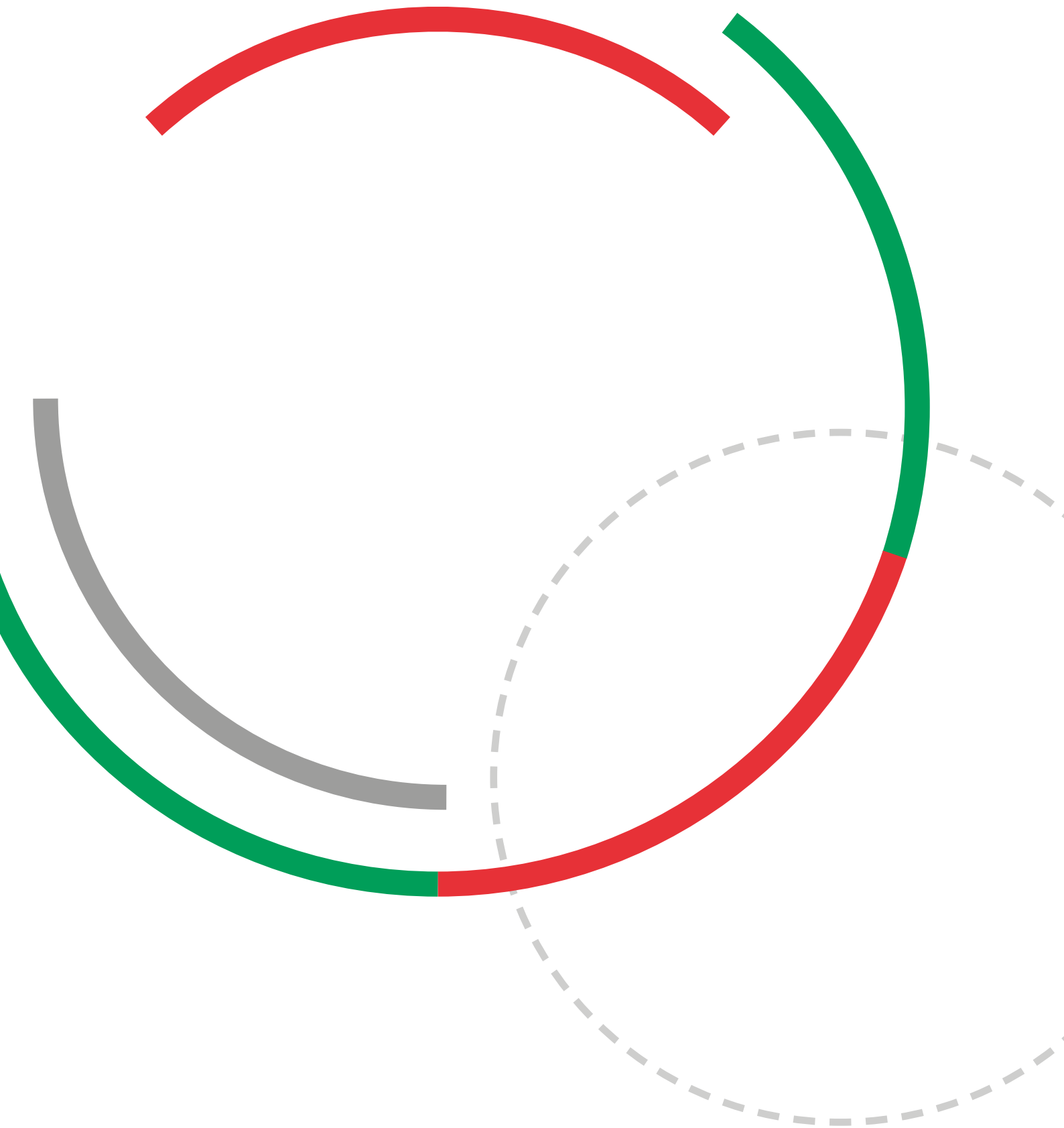

FERRATEC

Ferratec AG
Grossmattstrasse 19
8964 Rudolfstetten
Tel. 056 649 21 21
Fax 056 649 21 41
info@ferratec.ch
www.ferratec.ch